



# ASPEC Series

## Vertical Form, Fill & Seal Machine

“The ASPEC” is simple but reliable bagmaker proved by the Japanese packaging industry. The machine covers the general requirement from markets such as performance and bag formats with the accessible investment.

- Snack
- Cookie/Biscuit
- Confectionery
- Nuts/Cereal
- Pasta
- Pet food
- Ham/sausage
- Frozen food

### Dimensions

ASPEC-500

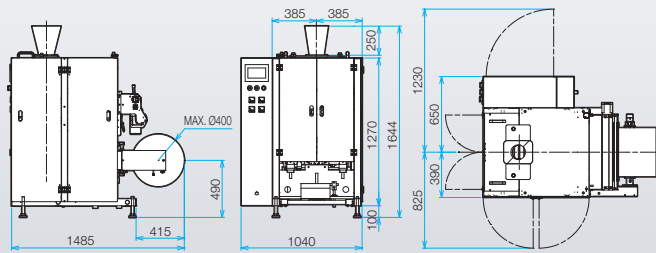

ASPEC-602S

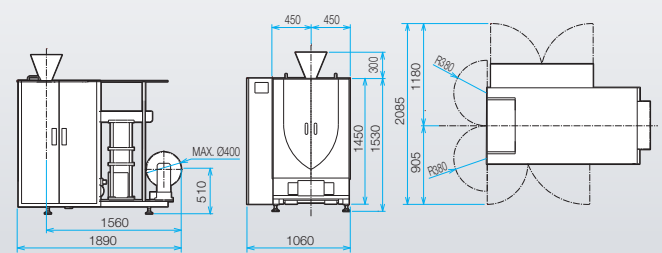

		ASPEC-500	ASPEC-500S	ASPEC-602S
Packing Speed		Max. 70 bpm	Max. 90 bpm	Max. 90 bpm
Bag Size (Max)		W 200 mm x L 300 mm		W 250 mm x L 300 mm
Packing Material		OPP/CPP, OPP/PE. Aluminun metallized PP, PET/PE, N/PE. etc.		
Film Web Size		W 140 - 450 mm x φ400mm		W 140 - 520 mm x φ400mm
Human Machine Interface		7 inches colored touch panel with bilingual indications		
Utilities	Air Consumption	0.5 Mpa / 500 NL / min		0.5 Mpa / 300 NL / min
	Power Wattage	6 kW 20 A		6 kW 30 A
	Power Supply	AC 200V, 50/60Hz, 3 phases (Separated transformer will be needed other than 200V )		
Operational Temperature		0-40 °C		
Machine Weight		500kg	510kg	900kg
Options		Data printer, Hole punch, N2 gas blowing, Take-up conveyor, Device for various bag formats, etc.		

Design and specifications are subject to change without notice.

# ASPEC -Series features and benefits

ASPEC VFFS bagmaker is affordable and easy-to-operate system that brings the higher quality to final products in the market. The proven technology by food packaging industries in Japan ensures the best usability and flexibility through the un-limited scope of applications.

## Quality seal integrity

- The high-power servo motor drive for opening-closing of sealing jaws ensures the adjustable sealing pressure and jaw open distance, which are necessary features to optimize the jaw settings based on the film structure and the bag size.
- Horizontal jaw obstruction detection ensures the machine stops running instantaneously in case of the product trapped in the seal.

## Flexible bag patterns

- ASPEC can handle major bag patterns in the market.

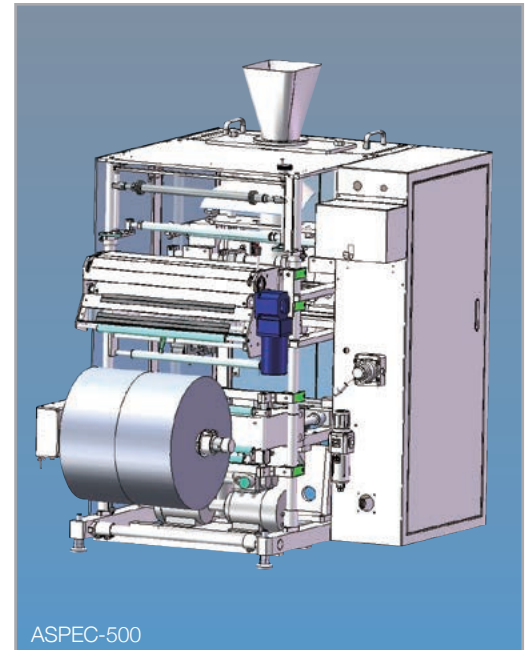
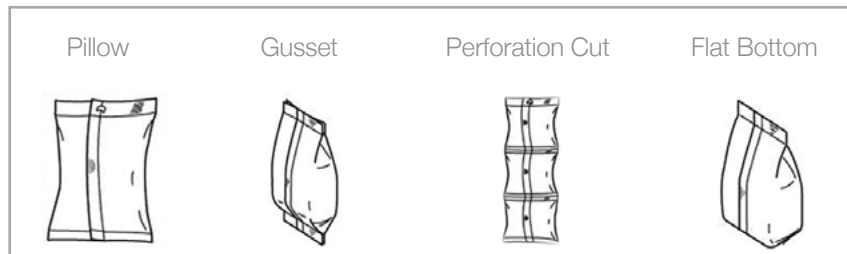

## Consistent and stable film flow

- Vacuum style pull-down belt incorporated with the double-servo motor film-feed drive prevents film from getting damages by the excessive film tension.
- This function ensures consistent and stable film flow to secure the identical bag's length.

## Easy product-changeover and simple operation

- HMI - 7 inches colored touch screen with selected language can store technical parameters for various bag types.
- No need to reset the machine during product-change over.

## Enhanced safety and error indicating

- Fully interlock guarding
- Film alarm device

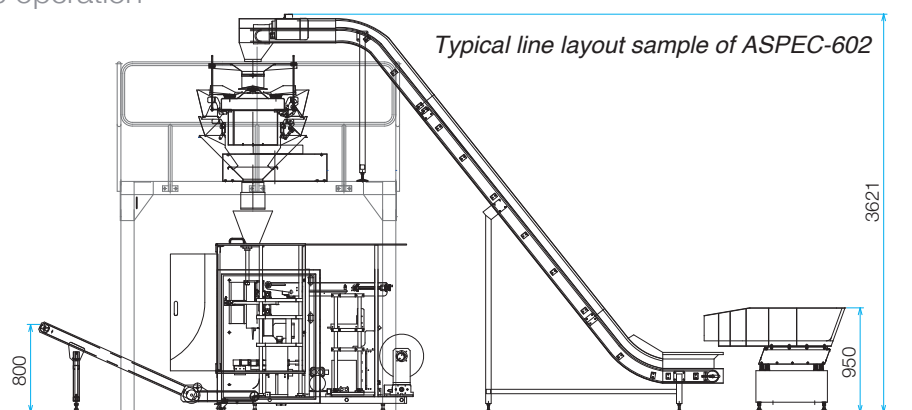

Distributed by **ISHIDA CO.,LTD.**

Contact Us.