

# e-mac

Electric. Efficient. Compact & precise.



**ENGEL**  
be the first



**ENGEL e-mac. A machine that gives you more. A machine that combines great performance with amazing precision.** All-electric. A machine that offers you a huge amount of freedom. Enough freedom to be able to design your individual injection moulding applications with the required degree of flexibility.

A machine that takes up very little shop floor space despite its amazing performance. And a machine that is extremely frugal. In ongoing operations, because it uses very little energy. But above all in terms of capital outlay – keyword: unbeatably inexpensive purchasing price.

**All-electric. Best-in-class efficiency and precision to the max.**

All of the ENGEL e-mac's movements are performed by servo-electric drives. The all-electric drive helps you to achieve best-in-class efficiency for the entire machine. Maximum precision of all movements and impressive process stability guarantee the highest levels of good parts.

**Flexible and modular. Many options and ENGEL CC300 control unit.**

The ENGEL e-mac uses the proven ENGEL CC300 control unit which offers maximum flexibility on all ENGEL machines. With the ENGEL e-mac you can also implement complex injection moulding applications in a highly efficient and user-friendly way. Thanks to fully-integrated automation, the proven ENGEL formula of „Robot control unit = Machine control unit“ applies here – in other words, you can simply control your robot via your machine.

**Saving space. Thanks to compact dimensions.**

The ENGEL e-mac helps you save space. Thanks to its extremely compact dimensions, the machine makes optimum use of your shop floor space, giving you more value for your money. This means: more performance per cubic metre. Or to put it another way: more machines, and thus more productivity per facility. Do you need an intelligent automation solution for your injection moulding application? The matching 6/7 extension package converts your ENGEL e-mac into a highly efficient production cell. One that still makes very frugal use of your shop floor space.

**Saving costs. High energy efficiency saves cash.**

Thanks to consistent use of all-electric drive technology with best-in-class efficiency, the ENGEL e-mac is a genuine energy saving champion. This high energy efficiency saves you cash. Shot for shot. This helps you keep your ongoing operative costs down to an amazingly low level.

**Fast. Faster. ENGEL e-mac. Breathtaking acceleration for maximum productivity.**

The ENGEL e-mac sets a new standard with up to 22 m/s<sup>2</sup> acceleration on the injection axis. Thanks to this, and many more impressive parameters, it guarantees short cycle times and maximum productivity in your operations.

# ENGEL e-mac **clamping unit**

Close to perfection.

## High precision, dynamic clamping drive.

Ensures short dry-cycle times and impressive productivity. And perfect integration with take-off units.

## Sensitive mould protection.

Protection against mould wear. For improved availability. ENGEL autoprotect.

## Automatic mould height determination.

Automatic mould height determination on the ENGEL e-mac saves tooling time and prevents incorrect settings. For each mould change. The mounting height of the mould is automatically determined by an intelligent program.

## Central clamping force measurement.

The ENGEL e-mac measures the clamping force via a sensor on the face plate and not on a single tie-bar, in contrast to legacy systems. Central measurement helps you achieve maximum measuring assurance.

## Linear guidance of the moving platen.

The moving platen on the ENGEL e-mac is guided in a virtually friction-free way. Instead of tie-bar guides, it relies on high-precision linear guides. This not only saves energy, it also increases the service life of the clamping unit. Worn tie-bars or bushings are thus a thing of the past.

## Automatic clamping force correction for high process assurance.

When the mould heats up and expands, the clamping force increases. Intelligent clamping force correction compensates for this effect. With a mind to continuous process assurance.



# ENGEL e-mac **injection unit**

Inject the future.

## High-precision sensors and fast control.

Highly precise and extremely fast - this is how the injection unit on the ENGEL e-mac works: for example, the screw position is measured by the encoders on the servo-motors. This ensures maximum resolution for highest precision and process assurance. Pressure membranes measure the peak, post-injection and holding pressures outside the nozzle area. This avoids the measured value being influenced by different processing temperatures.

## Powerful servo-motors.

ensure high injection speeds and breathtaking acceleration. And: they allow for long, high post-injection pressures.

## Longer service life, less maintenance overhead thanks to oil sump lubrication of the spindles.

The spindles on the injection unit are optimally lubricated, being encapsulated and running in an oil sump. This extends the spindle service life and keeps the entire area clean. Another benefit: the spindles are highly efficient as there is no need for oil cooling. And you make substantial savings on maintenance costs, as this lubrication system uses inexpensive standard oil.



## Saving tooling time.

Swivel-out injection unit included as standard – this means optimum accessibility of the screw tip and minimal overhead for changing and cleaning the screws. But barrels can also be changed quickly on the ENGEL e-mac. Thanks to the intelligent quick-coupling system. All told, this saves you much valuable tooling time.

## Intelligent contact force system.

Force is applied symmetrically by two spindles. The contact force, which is held by the motor brake, is configurable and can be precisely adjusted to match each mould. The nozzle movement is configurable via a profile. Parallel motion means valuable cycle time savings.

# ENGEL e-mac advantages

## Clamping drive: high productivity, precision and dynamic

Short dry-cycle times for impressive productivity. This is what the dynamic clamping drive with its optimised toggle lever geometry offers. Due to FEM (Finite Element Method) optimised parts, only very little mass is moved. This improves the dynamic while at the same time reducing the energy consumption.

## Sensitive mould protection ENGEL autoprotect

Maximum safety for your mould. This is guaranteed by the self-teaching and highly-sensitive ENGEL autoprotect mould protection program. It automatically determines the mould protection force and can be set up individually for each mould. Mould wear and maintenance costs are thus reduced to a minimum. And machine availability, and thus productivity increase substantially.

## Highest injection performance

To achieve the maximum injection speed at the highest injection pressures, extremely powerful servo-motors are required. The ENGEL e-mac again sets standards in its class. Thin wall thicknesses and long flow channels are thus child's play for the high-performance injection units on the machine.

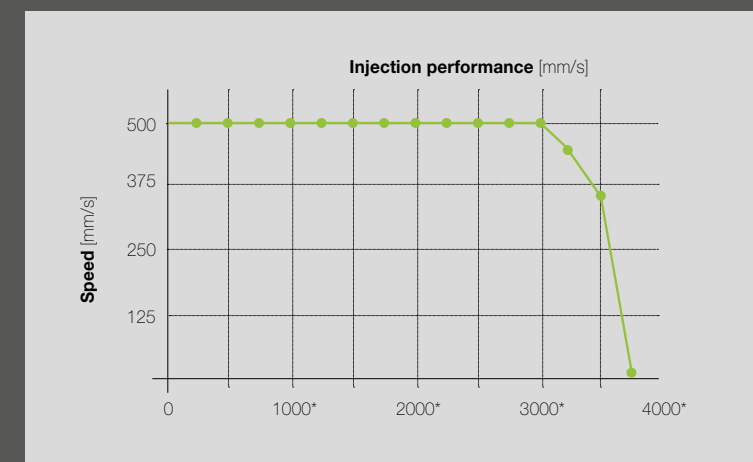
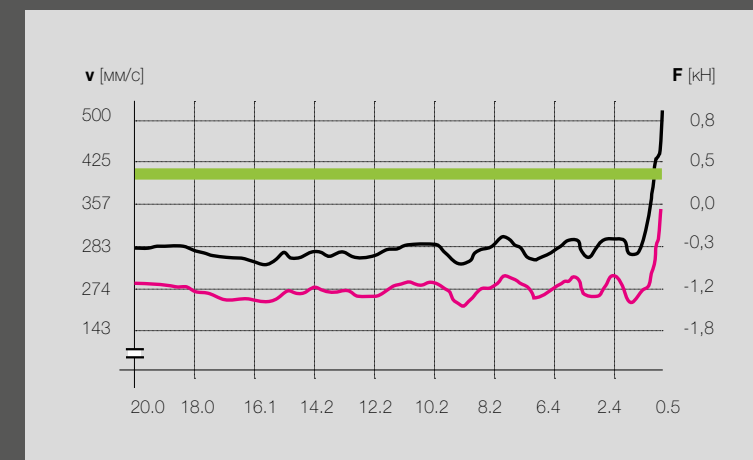
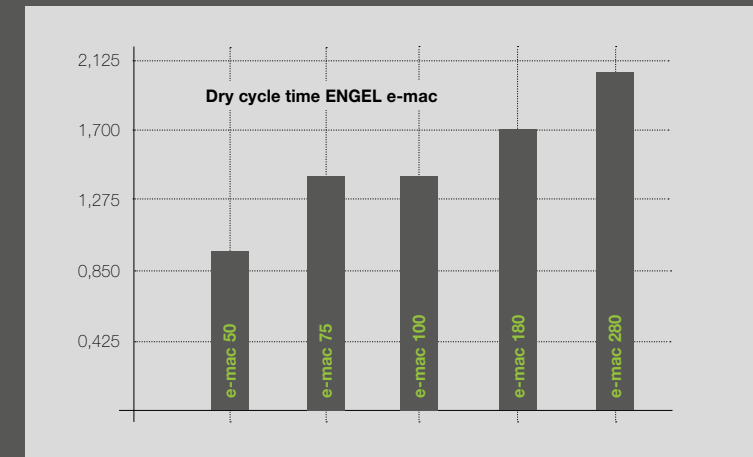

\*Theoretical values



## Dynamic ejector - precise and dynamic

The ENGEL e-mac is equipped with a servo-electric ejector as standard equipment. This means that parallel motion of the ejector can be optimally adjusted to match the mould movements. Thanks to fast acceleration behaviour and high reproducibility of the ejector positions, the mould take-off process can be accelerated, thus saving cycle time.

## Taking precision to the highest level

High-quality sensors and fast controls are required for highest precision and repeating accuracy. This is the only way to control a dynamic injection process. The ENGEL e-mac offers the best prerequisites for this. All pertinent positions are measured with highest resolutions via the increment shaft encoders on the servo-motors. This guarantees positioning repeatability of  $\pm 0.02$  mm. The peak, post-injection and holding pressure measurement is not influenced by external factors; it occurs directly on the screw bearing and thus has a direct mechanical connection to the melt pre-chamber via the screw. The pressure sensor is wear-free and calibrated for its entire service life - it impresses with its extremely high resolution. This guarantees maintenance-free long-term precision.



## Long post-injection pressure – no problem!

Long, high post-injection pressures can be a major challenge for electric machines. The motor and controller overheat after a short time at high pressures and the post-injection pressure collapses. The rule is: the more powerful the motor, the better the post-injection pressure behaviour. And here too the ENGEL e-mac sets new standards in its class.

## ENGEL iQ weight control.

Smart online process control.  
An intelligent option.

ENGEL's newly developed iQ weight control software automatically detects viscosity fluctuations and compensates for them in the same shot. The results: substantially improved reproducibility of the process and part weight. Or to put this another way: more good parts, less rejects and thus higher productivity!

Even if the ambient conditions change: the quality of your moulded parts remains consistently high. Shot for shot.

## ENGEL smart shut

The non-return valve with forced shut-off.

Although state-of-the-art electric injection units are proven to execute movements at the highest levels of repeatability, shut-off behaviour is the decisive factor in maintaining process consistency. The forced shut-off action of the ENGEL smart shut reduces weight fluctuation to a minimum.

This is how the new intelligent solution – ENGEL smart shut – works: after the metering process, the screw is turned briefly in the opposite direction; a special control gate moves the lantern piece in shut-off direction. The non-return valve is thus already closed before the injection action.

The advantage: thanks to ENGEL smart shut, different shut-off points and the weight fluctuations they cause are a thing of the past.



The powerful servo-motors can easily hold **long post-injection pressures**.

Injection unit	Screw	Post injection pressure without time limit
50	15 mm	1520 bar
170	22 mm	1865 bar
310	30 mm	1415 bar
440	35 mm	1295 bar
740	45 mm	1010 bar
940	50 mm	960 bar
1340	55 mm	1050 bar

Thin-walled LCD display frame (POM):  
**85% reduction in weight variance**

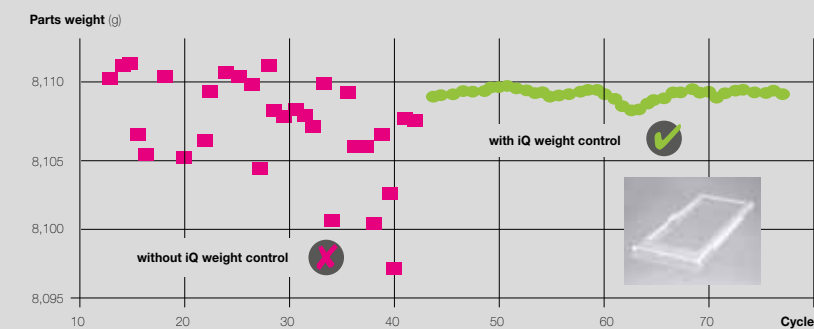

The **smart shut return** flow shut-off device achieves far **lower weight fluctuation**.

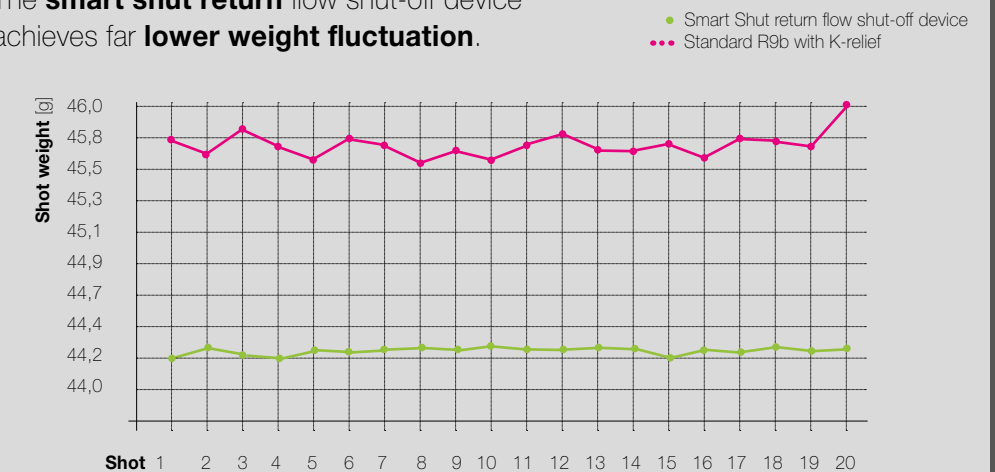

# ENGEL e-mac 50

## ENGEL e-mac 50 Clamping unit

	e-mac 50	
Clamping force	kN	500
Opening force	kN	60
Max. opening stroke	mm	260
Mould installation height min/max	mm	150/350
Max. platen distance	mm	610
Tie-bar gap	mm	370 x 320
Mould fixing platen	mm	520 x 470
Mould weight max	kg	480
Ejector stroke	mm	100
Ejector force	kN	22
Dry cycle time	sec/mm	1,0/25

## ENGEL e-mac 50 Injection unit

		50			170		
Screw diameter	mm	15	18	20	22	25	30
L/D screw length	L/D	24	24	24	24,8	24,8	20,5
Injection pressure max.	bar	2400	2400	2000	2400	2400	2000
Screw stroke	mm	80			120		
Stroke volume	cm <sup>3</sup>	14,1	20,4	25,1	46	59	85
Injection part weight max. (PS)	g	13	19	23	42	54	78
Injection rate	cm <sup>3</sup> /s	58	84	104	84	109	157
Injection rate High	cm <sup>3</sup> /s	88	127	157	126	163	235
Injection rate Premium	cm <sup>3</sup> /s				171	221	318
Screw speed	min-1	450			400		
Screw torque	Nm	45	75	120	171	230	300
Plasticising capacity	g/s	2,8	4,2	6	6,4	10	14,2
Nozzle stroke	mm	200			225		
Nozzle contact force	kN	20			28		
Number of heating zones		4			4		
Installed heat output	kW	4,3	5,1	5,8	6,1	7	7
Weight	to	3,1			3,2		
Rated power	kW	12/14/-			14/15/18		

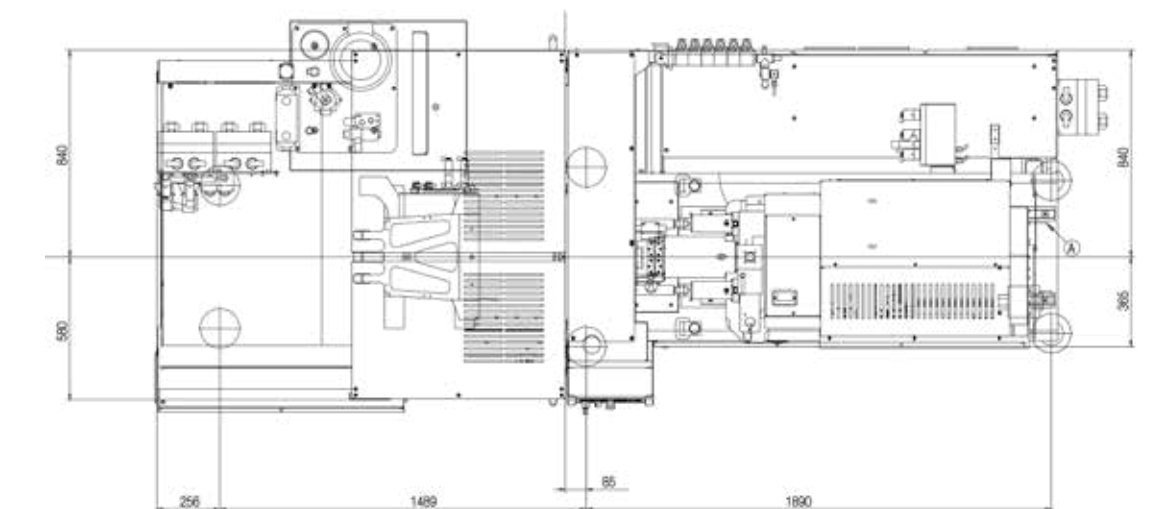
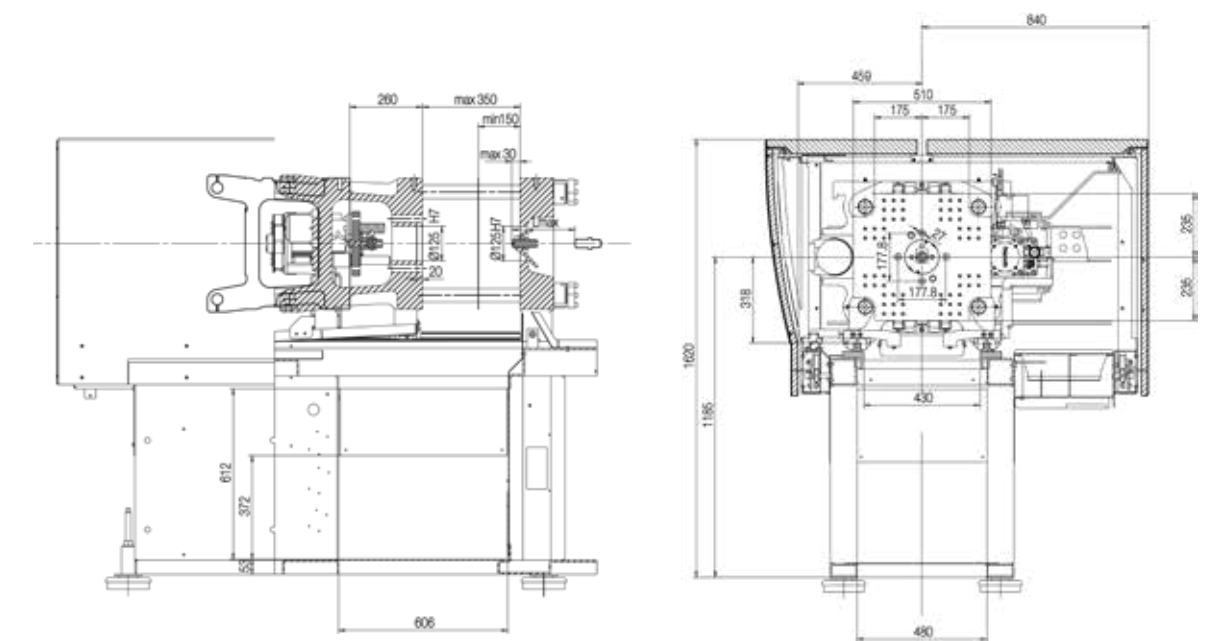
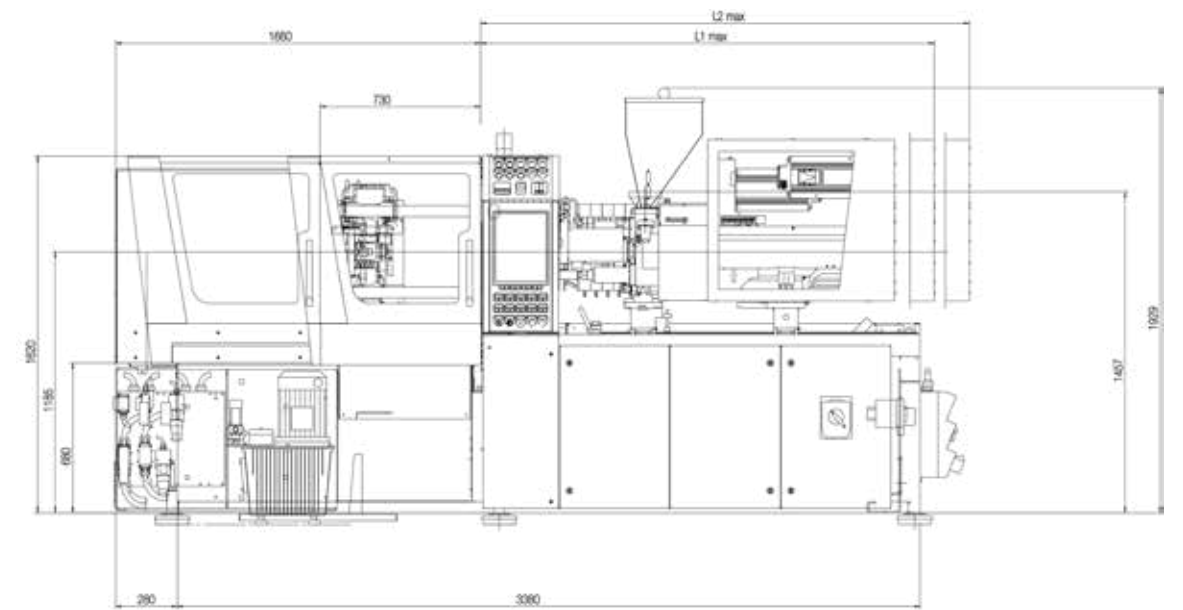



# ENGEL e-mac 75

## ENGEL e-mac 75 Clamping unit

			e-mac 75
Clamping force	kN		750
Opening force	kN		75
Max. opening	mm		350
Mould installation height min/max	mm		150/450
Max. platen distance	mm		800
Tie-bar gap	mm		460 x 410
Mould fixing platen	mm		650 x 600
Mould weight max	kg		1000
Ejector stroke	mm		100
Ejector force	kN		22
Dry cycle time	sec/mm		1,4/320

## ENGEL e-mac 75 Injection unit

		75			310	
Screw diameter	mm	22	25	30	30	35
L/D screw length	L/D	24,8	24,8	20,5	23,6	20
Injection pressure max.	bar	2400	2400	2000	2400	2400
Screw stroke	mm	120			160	
Stroke volume	cm <sup>3</sup>	46	59	85	113	154
Injection part weight max. (PS)	g	42	54	78	104	142
Injection rate	cm <sup>3</sup> /s	84	109	157	157	214
Injection rate High	cm <sup>3</sup> /s	126	163	235	235	320
Injection rate Premium	cm <sup>3</sup> /s	171	221	318	326	444
Screw speed	min-1	400			420	
Screw torque	Nm	171	230	300	450	450
Plasticising capacity	g/s	6,4	10	14,2	14,7	22,1
Nozzle stroke	mm	225			225	
Nozzle contact force	kN	28			28	
Number of heating zones		4			4	
Installed heat output	kW	6,1	7	7	9,2	9,2
Weight	to	4,4			4,8	
Rated power	kW	14/15/18			17/18/19	

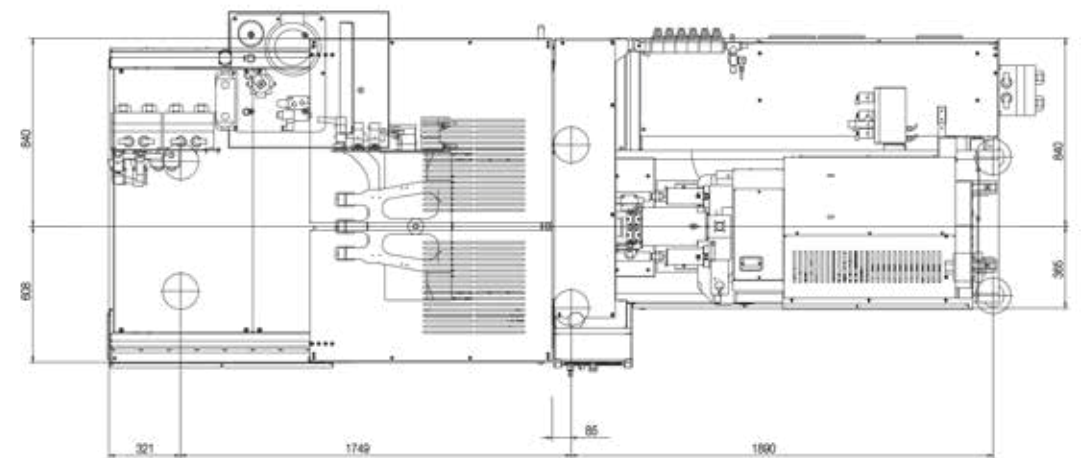
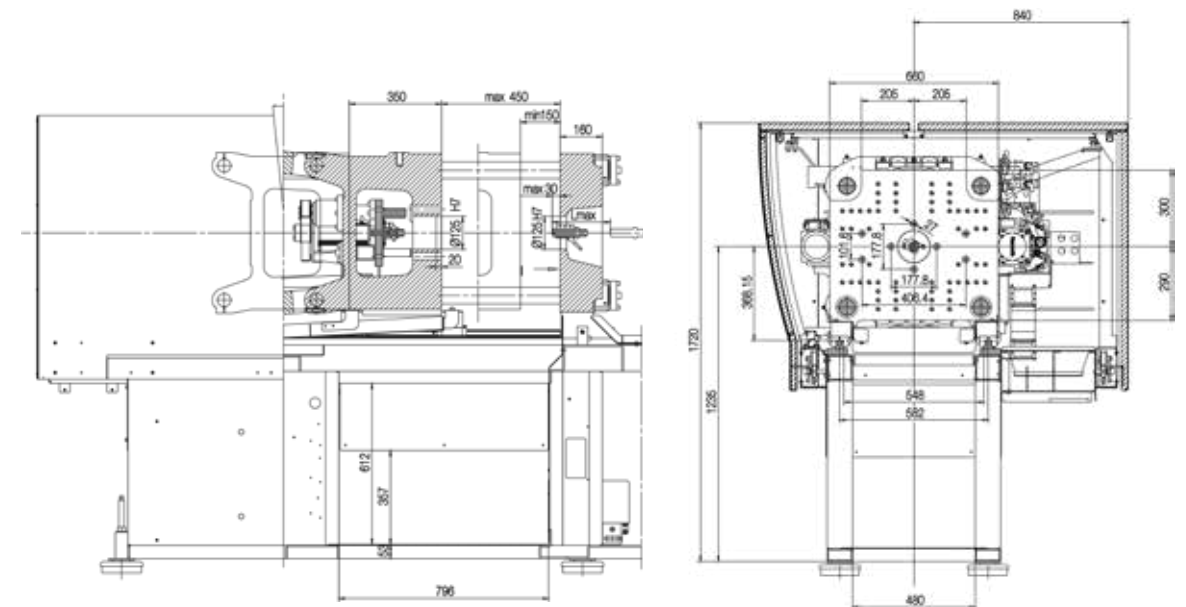
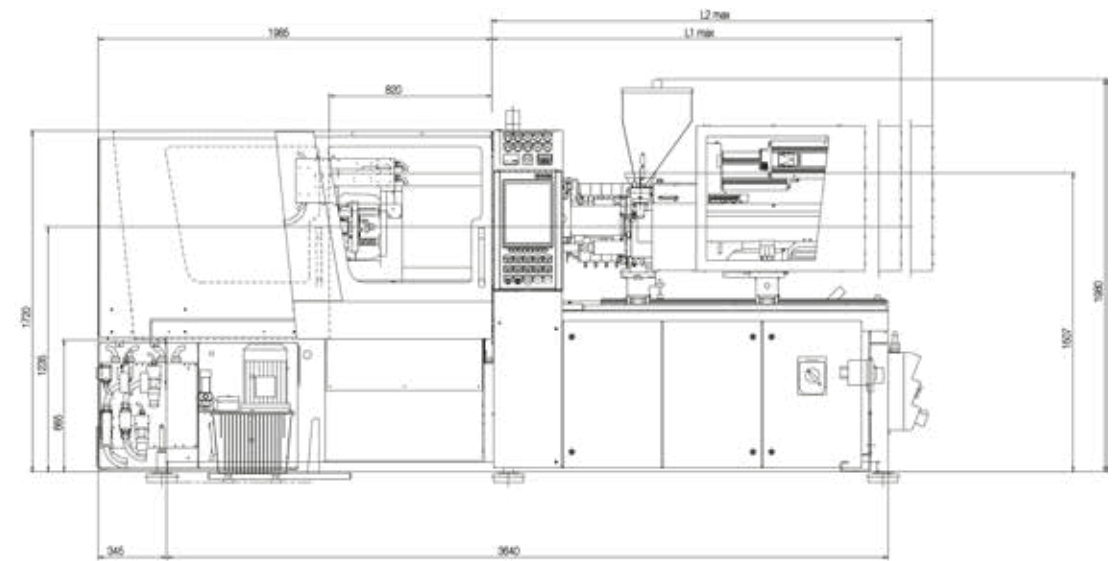

# ENGEL e-mac 100

## ENGEL e-mac 100 Clamping unit

		e-mac 100	
Clamping force	kN		1000
Opening force	kN		100
Max. opening	mm		350
Mould installation height min/max	mm		150/450
Max. platen distance	mm		800
Tie-bar gap	mm		460 x 410
Mould fixing platen	mm		650 x 600
Mould weight max	kg		1000
Ejector stroke	mm		100
Ejector force	kN		22
Dry cycle time	sec/mm		1,4/320

## ENGEL e-mac 100 Injection unit

		75			310		440	
Screw diameter	mm	22	25	30	30	35	35	40
L/D screw length	L/D	24,8	24,8	20,5	23,6	20	20	20
Injection pressure max.	bar	2400	2400	2000	2400	2000	2400	2000
Screw stroke	mm	120			160		175	
Stroke volume	cm <sup>3</sup>	46	59	85	113	154	168	220
Injection part weight max. (PS)	g	42	54	78	104	142	155	202
Injection rate	cm <sup>3</sup> /s	84	109	157	157	214	171	224
Injection rate High	cm <sup>3</sup> /s	126	163	235	235	320	258	337
Injection rate Premium	cm <sup>3</sup> /s	171	221	318	326	444	435	568
Screw speed	min-1	400			420		420	
Screw torque	Nm	171	230	300	450	450	605	605
Plasticising capacity	g/s	6,4	10	14,2	14,7	22,1	22,1	33,6
Nozzle stroke	mm	225			225		305	
Nozzle contact force	kN	28			28		28	
Number of heating zones		4			4		4	
Installed heat output	kW	6,1	7	7	9,2	9,2	9,2	9,2
Weight	to	4,4			4,8		4,8	
Rated power	kW	14/15/18			17/18/19		18/20/22	

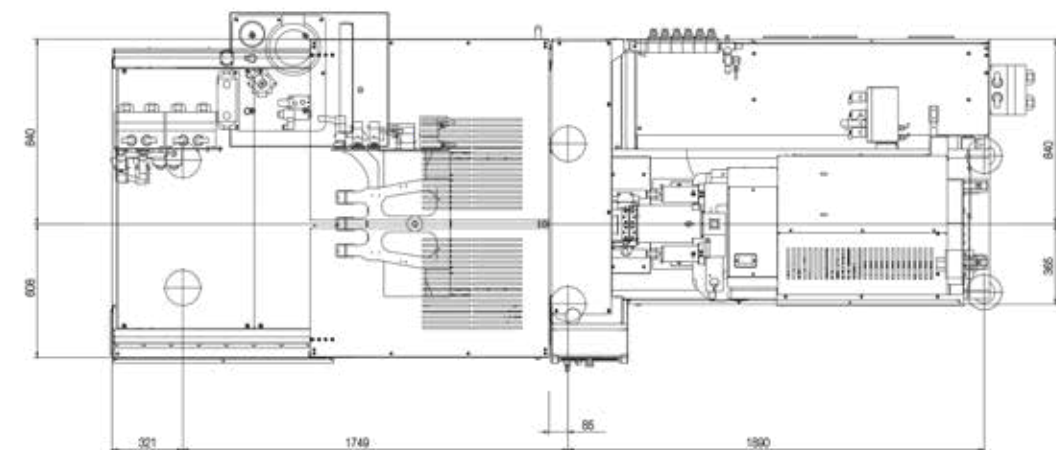
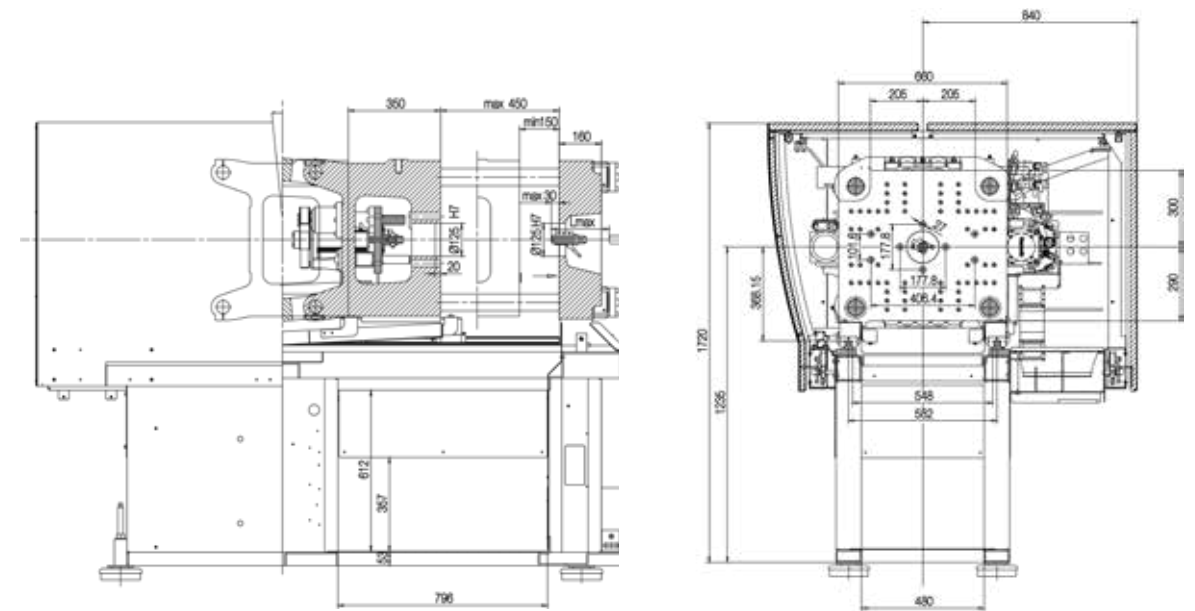
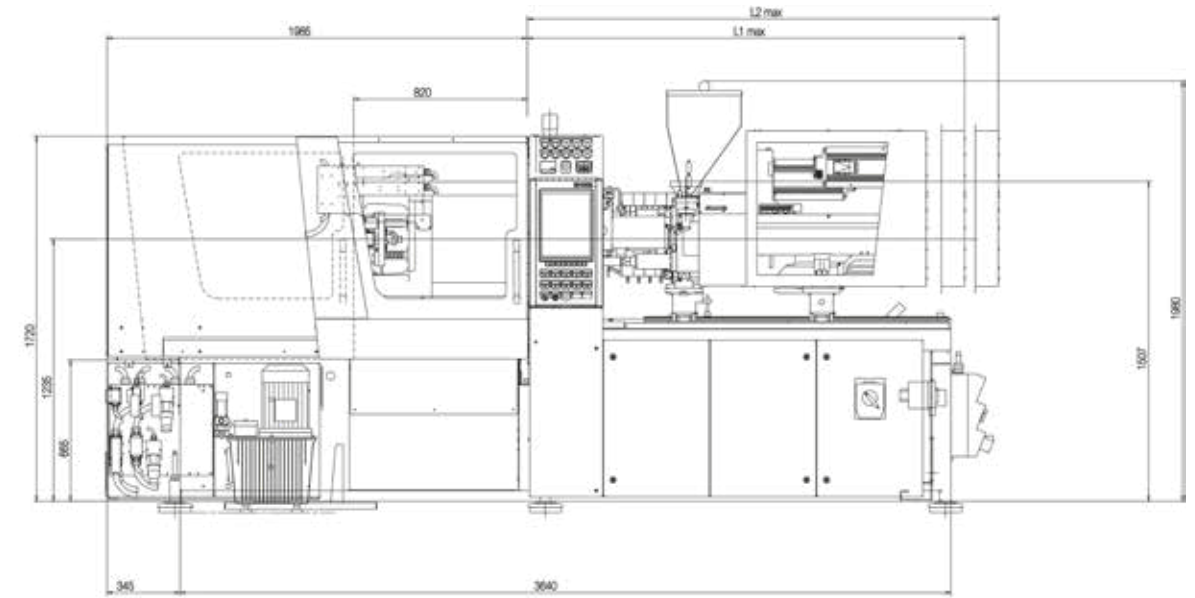

# ENGEL e-mac 180

## ENGEL e-mac 180 Clamping unit

		e-mac 180
Clamping force	kN	1800
Opening force	kN	180
Max. opening	mm	460
Mould installation height min/max	mm	250/600
Max. platen distance	mm	1060
Tie-bar gap	mm	520 x 520
Mould fixing platen	mm	760 x 760
Mould weight max	kg	1900
Ejector stroke	mm	130
Ejector force	kN	37
Dry cycle time	sec/mm	1,7/320

## ENGEL e-mac 180 Injection unit

		310		440		740			940		
Screw diameter	mm	30	35	35	40	45	50	55	50	55	60
L/D screw length	L/D	23,6	20	20	20	20	20	20	20	20	20
Injection pressure max.	bar	2400	2000	2400	2000	2400	2000	1650	2200	1810	1520
Screw stroke	mm	160		175		200			220		
Stroke volume	cm <sup>3</sup>	113	154	168	220	318	392	475	432	522	622
Injection part weight max. (PS)	g	104	142	155	202	291	359	435	396	479	571
Injection rate	cm <sup>3</sup> /s	157	214	171	224	280	346	418	291	352	418
Injection rate High	cm <sup>3</sup> /s	235	320	258	337	530	654	791	595	720	857
Injection rate Premium	cm <sup>3</sup> /s	326	444	435	568	733	905	1095	915	1107	1318
Screw speed	min-1	420		420		300			267		
Screw torque	Nm	450	450	605	605	900	900	900	1470	1470	1470
Plasticising capacity	g/s	14,7	22,1	22,1	33,9	31	42	56	37	50	32
Nozzle stroke	mm	225		305		400			400		
Nozzle contact force	kN	28		28		50			50		
Number of heating zones		4		4		5			5		
Installed heat output	kW	9,2	9,2	9,2	9,2	13,3	15,3	16,3	15,3	16,3	18,3
Weight	to	7,5		7,5		8,2			8,2		
Rated power	kW	20/21,5/23,5		21/23/24		27,8/31/34			29/32/36		

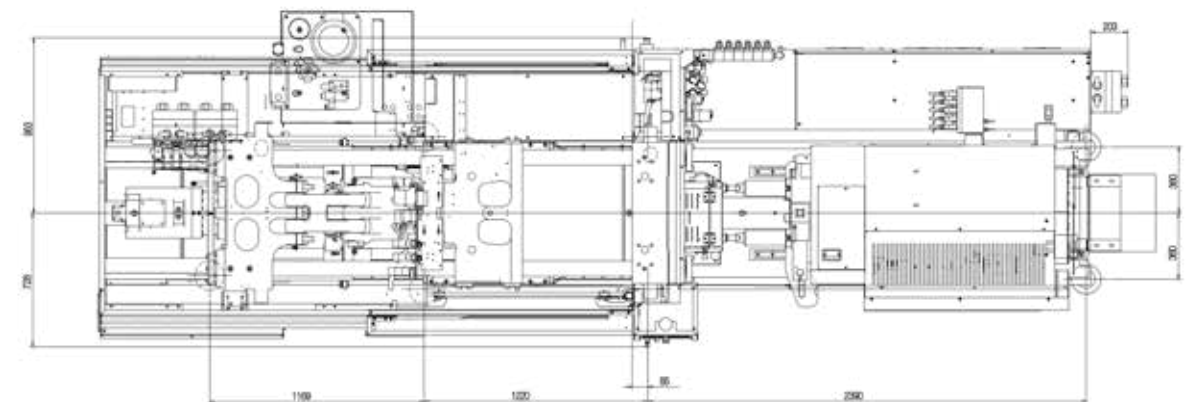
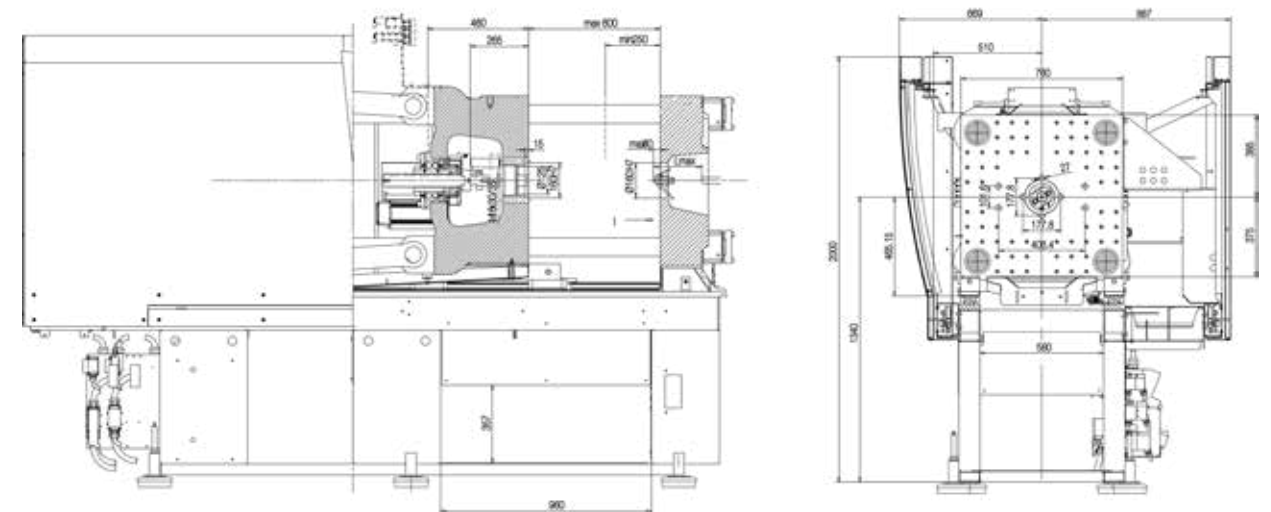
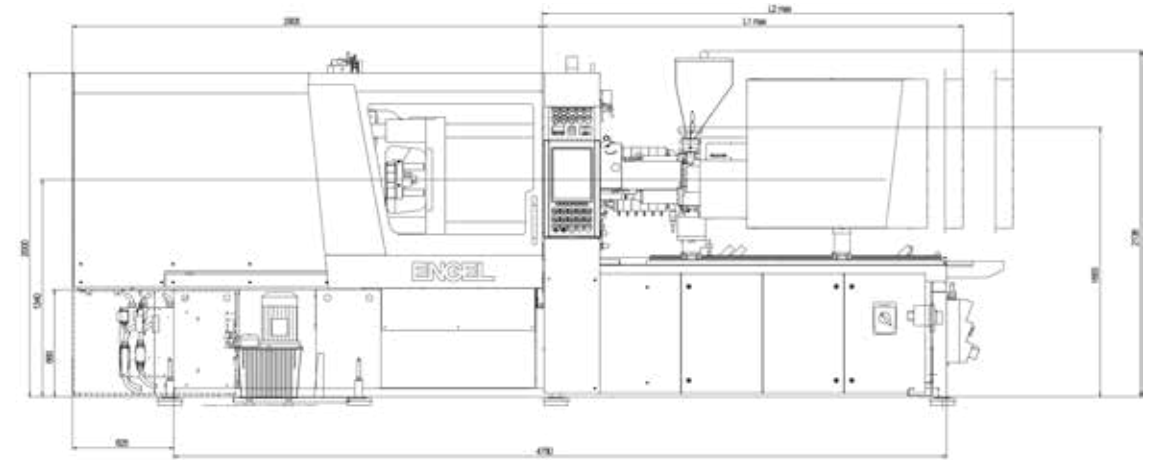

# ENGEL e-mac 280

## ENGEL e-mac 280

### Clamping unit

		e-mac 280	
Clamping force	kN	2800	
Opening force	kN	280	
Max. opening	mm	600	
Mould installation height min/max	mm	250/600	
Max. platen distance	mm	1200	
Tie-bar gap	mm	730 x 730	
Mould fixing platen	mm	1070 x 1070	
Mould weight max	kg	2400/200	
Ejector stroke	mm	200	
Ejector force	kN	77/77	
Dry cycle time	sec/mm	2,1/420	

## ENGEL e-mac 280

### Injection unit

		440				740				940				1340											
Screw diameter	mm	35	40	45	50	55	50	55	60	55	60	70	35	40	45	50	55	50	55	60	55	60	70		
L/D screw length	L/D	20	20	20	20	20	20	20	20	20	20	20	20	20	20	20	20	20	20	20	20	20	20		
Injection pressure max.	bar	2400	2000	2400	2000	1650	2200	1810	1520	2300	1930	1420	2400	2000	2400	2000	1650	2200	1810	1520	2300	1930	1420		
Screw stroke	mm	175				200				220				240				260				-			
Stroke volume	cm <sup>3</sup>	168	220	318	392	475	432	522	622	617	735	1000	168	220	318	392	475	432	522	622	617	735	1000		
Injection part weight max. (PS)	g	155	202	291	359	435	396	479	571	-				155	202	291	359	435	396	479	571	-			
Injection rate	cm <sup>3</sup> /s	171	224	280	346	418	291	352	418	511	608	827	171	224	280	346	418	291	352	418	511	608	827		
Injection rate High	cm <sup>3</sup> /s	258	337	530	654	791	595	720	857	736	876	1193	258	337	530	654	791	595	720	857	736	876	1193		
Injection rate Premium	cm <sup>3</sup> /s	435	568	-				-				-				435	568	-				-			
Screw speed	min <sup>-1</sup>	420				300				267				250				420	300	267	250	420	300	267	250
Screw torque	Nm	605	605	900	900	900	1470	1470	1470	1850	1850	1850	605	605	900	900	900	1470	1470	1470	1850	1850	1850		
Plasticising capacity	g/s	22,1	33,9	31	42	56	37	48	59	45	56	82	22,1	33,9	31	42	56	37	48	59	45	56	82		
Nozzle stroke	mm	305				400				400				400				305	400	400	400	305	400	400	400
Nozzle contact force	kN	28				50				50				50				28	50	50	50	28	50	50	50
Number of heating zones		4				5				5				5				4	5	5	5	4	5	5	5
Installed heat output	kW	9,2	9,2	13,3	15,3	16,3	15,3	16,3	18,3	19,8	21,3	24,3	9,2	9,2	13,3	15,3	16,3	15,3	16,3	18,3	19,8	21,3	24,3		
Weight	to	15,6				16,5				16,5				18				15,6	16,5	16,5	18	15,6	16,5	16,5	18
Rated power	kW	30/30/42				36/46/-				44/54/-				73/84/-				30/30/42	36/46/-	44/54/-	73/84/-	30/30/42	36/46/-	44/54/-	73/84/-

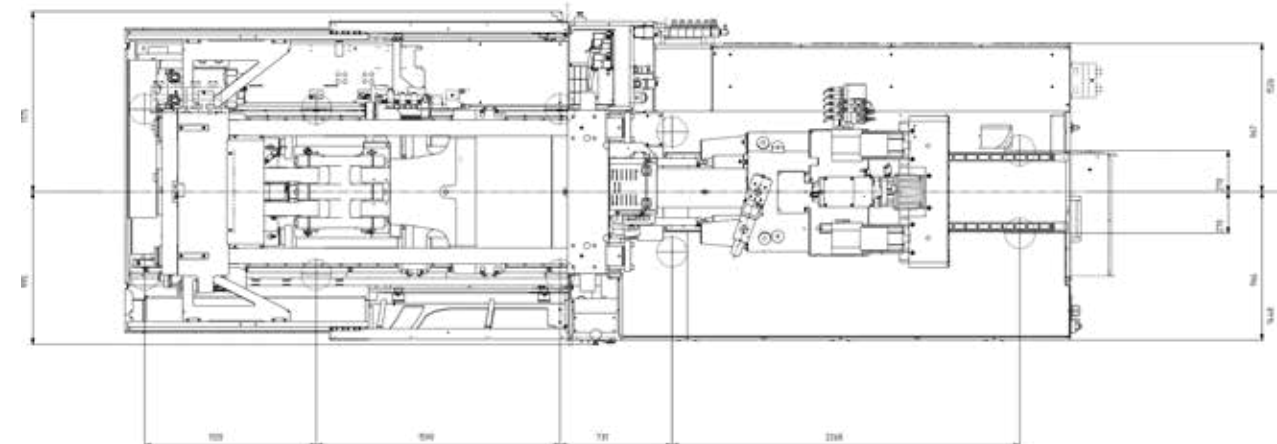
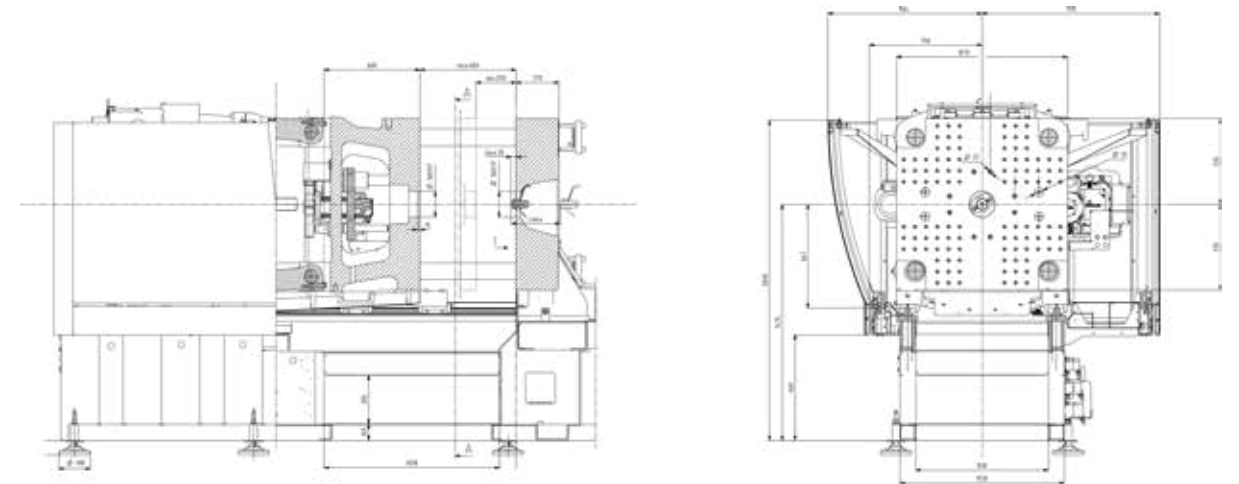
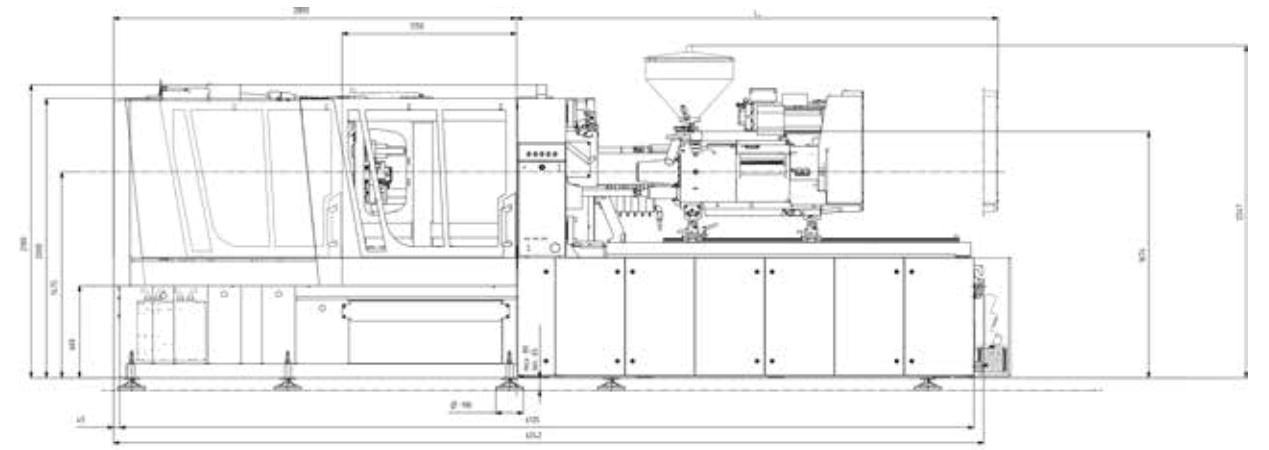



ENGEL AUSTRIA GmbH | Ludwig-Engel-Straße 1 | 4311 Schwertberg, Austria  
Tel. +43 50 620 0 | Fax +43 50 620 3009 | sales@engel.at | [www.engelglobal.com](http://www.engelglobal.com)

The information, product features and pictures contained in this brochure are intended exclusively as a technical guide. ENGEL is not responsible for any technical changes or print/typographical errors. Reproduction in whole or in part is prohibited without the prior written consent of ENGEL AUSTRIA GmbH.